

Demonstration Board EPC9107

Quick Start Guide

28 V Buck Converter featuring EPC2015



DESCRIPTION

www.epc-co.com

The EPC9107 demonstration board is a 3.3 V output, 1 MHz buck converter with an 15 A maximum output current and 9 V to 28 V input voltage range. The demonstration board features the EPC2015 enhancement mode (*eGaN*[®]) field effect transistor (FET), as well as the Texas Instruments LM5113 gate driver.

The EPC9107 board contains the complete power stage (including eGaN FETs, driver, inductor and input/output caps) in a compact ½" x ½" layout to showcase the performance that can be achieved using the *eGaN* FETs and *eGaN* driver together.

The EPC9107 demonstration board is 3" square and contains a fully closed loop buck converter with optimized control loop.

There are also various probe points to facilitate simple waveform measurement and efficiency calculation. A complete block diagram of the circuit is given in Figure 1. For more information on the EPC2015 *eGaN* FETs or LM5113 driver, please refer to the datasheet available from EPC at www.epc-co.com and www.ti.com. These datasheets, as well that of the LT3833 controller should be read in conjunction with this quick start guide.

Table 1: Performance Summary (TA = 25 °C)

| SYMBOL | PARAMETER | CONDITIONS | MIN | TYP | MAX | UNITS |
|------------------|----------------------------|--|-----|------|-----|-------|
| V _{IN} | Bus Input Voltage Range | | 9 | | 28 | V |
| V _{OUT} | Switch Node Output Voltage | | | 3.3 | | V |
| I _{OUT} | Switch Node Output Current | | | | 15* | A |
| f _{SW} | Switching frequency | | | 1000 | | kHz |
| | Peak Efficiency | 12 V _{IN} 10 A I _{OUT} | | 96.1 | | % |
| | Peak Efficiency | 28 V _{IN} 12 A I _{OUT} | | 93.5 | | % |
| | Full Load Efficiency | 12 V _{IN} 15 A I _{OUT} | | 95.6 | | % |
| | Full Load Efficiency | 28 V _{IN} 15 A I _{OUT} | | 93.3 | | % |

* Maximum limited by inductor saturation

Quick Start Procedure

Demonstration board EPC9107 is easy to set up to evaluate the performance of the EPC2015 *eGaN* FETs and LM5113 driver. Refer to Figure 2 for proper connect and measurement setup and follow the procedure below:

1. With power off, connect the input power supply bus between V_{IN} and GND banana jacks as shown.
2. With power off, connect the active (constant current) load as desired between V_{OUT} and GND banana jacks as shown.
3. Turn on the supply voltage to the required value (more than 9V, but do not exceed the absolute maximum voltage of 28 V on V_{IN}).
4. Measure the output voltage to make sure the board is fully functional and operating no-load.
5. Turn on active load to the desired load current while staying below the maximum current (15 A)
6. Once operational, adjust the bus voltage and load current within the allowed operating range and observe the output switching behavior, efficiency and other parameters.
7. For shutdown, please follow steps in reverse.

NOTE. When measuring the high frequency content switch node of gate voltage, care must be taken to avoid long ground leads. Measure these by placing the oscilloscope probe tip on the top pad of D3 and grounding the probe directly across D3 on the bottom pad provided for switch node and using the right hand pad of R24 and the GND pad below it for gate voltage. See Figure 3 for proper scope probe technique. Measuring the switch node with a high bandwidth ($\geq 500\text{MHz}$) probe and high bandwidth scope ($\geq 1\text{GHz}$) is recommended.

NOTE. The dead-times for both the leading and trailing edges have been set for optimum full load efficiency. Adjustment is not recommended, but can be done at own risk by replacing R21 and R22 with potentiometers P1 and P2. This should be done while monitoring both the input current and switch-node voltage to determine the effect of these adjustments. Under no circumstance should the input pins to the LM5113 be probed during operation as the added probe capacitance will change the device timing.

CIRCUIT PERFORMANCE

The EPC9107 demonstration circuit was designed to showcase the size and performance that can readily be achieved at 1 MHz operation using *eGaN* FETs for supply voltages up to 28V or more. Since a closed loop controller is included on board, the associated losses must also be lumped into any efficiency measurement that is performed. In an effort to mitigate these losses and focus on the efficiency of the power stage, the controller is powered from the output through an unregulated charge pump supplied from the output. Thus the controller and gate drive losses are still included, but the associated conversion loss from the input supply is improved.

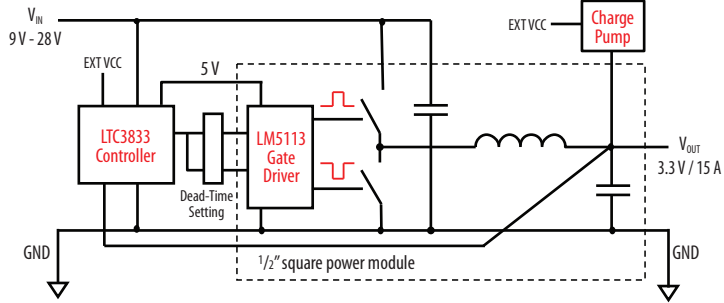

Figure 1: Block Diagram of EPC9107 Demonstration Board

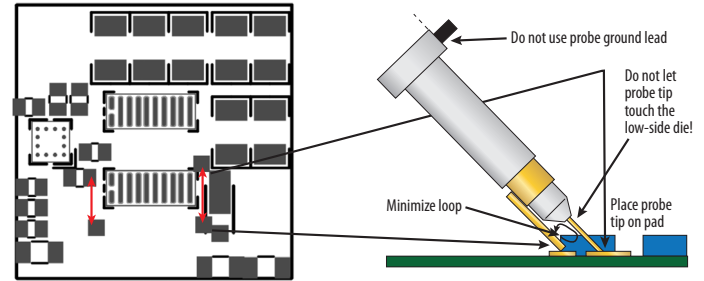

Figure 3: Proper Measurement of Switch Node or Gate Voltage

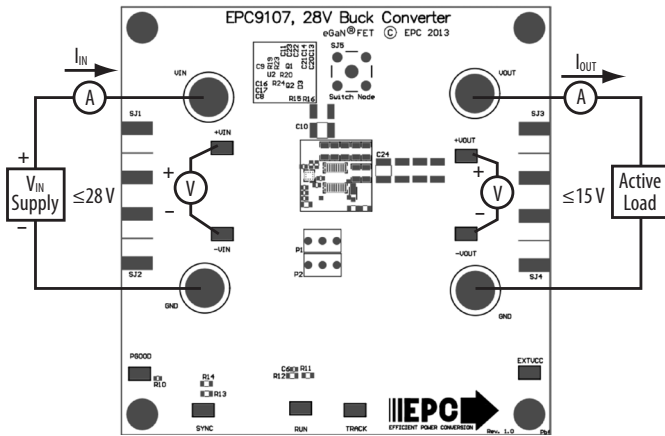

Figure 2: Proper Connection and Measurement Setup

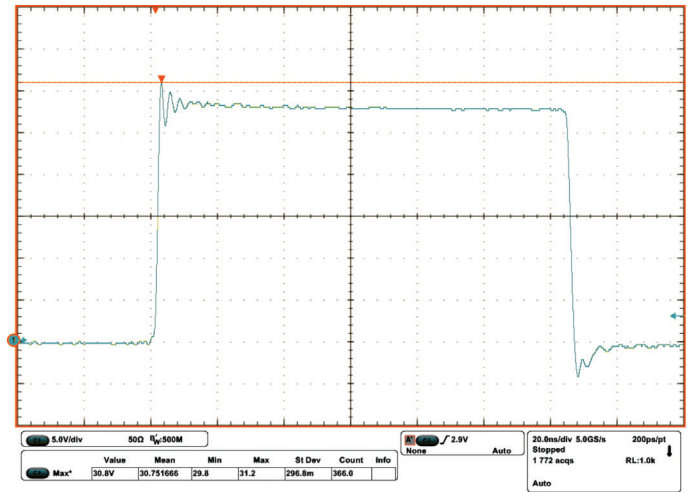

Figure 4: Typical waveforms for 28 V to 3.3 V / 15 A (1 MHz) CH1: Switch node voltage

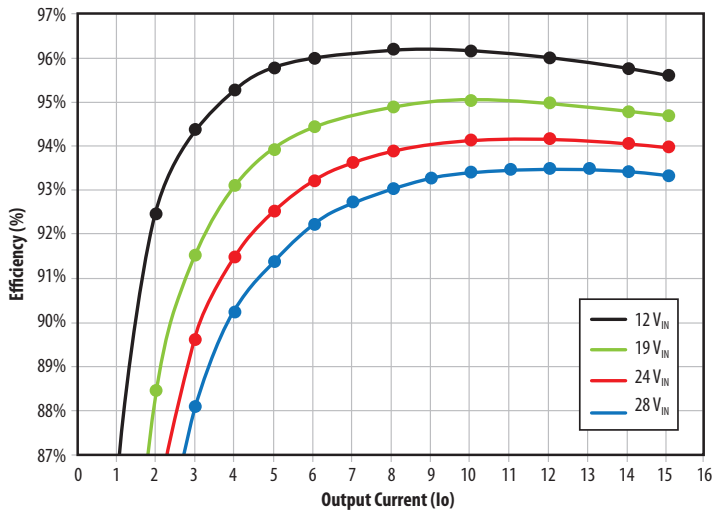
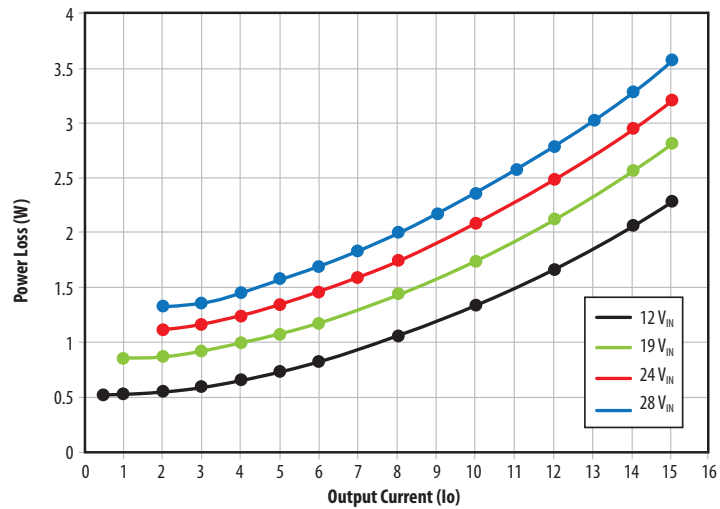

Figure 5: Typical efficiency and power loss curves for 12V, 19V, 24V and 28V input



THERMAL CONSIDERATIONS

The EPC9107 demonstration board thermal image for steady state full load operation is shown in Figure 6. The EPC9107 is intended for bench evaluation with low ambient temperature and convection cooling. The addition of heat-sinking and forced air cooling could increase the current capability of the demonstration circuit, but care must be taken to not exceed the absolute maximum die temperature of 125°C and stay within the constraints of the other components within the circuit, most notably the saturation of the output inductor.

NOTE: The EPC9107 demonstration board does not have any thermal protection on board.

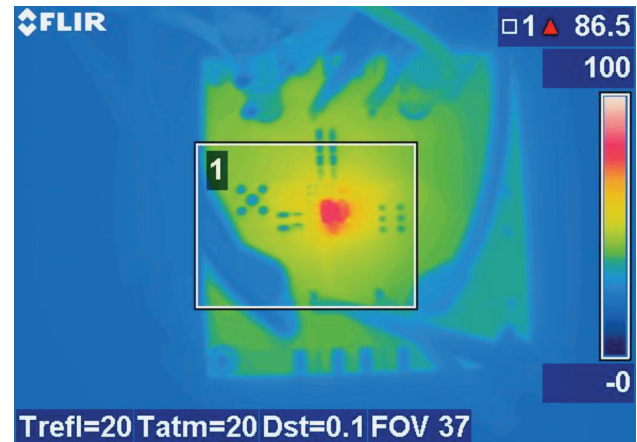
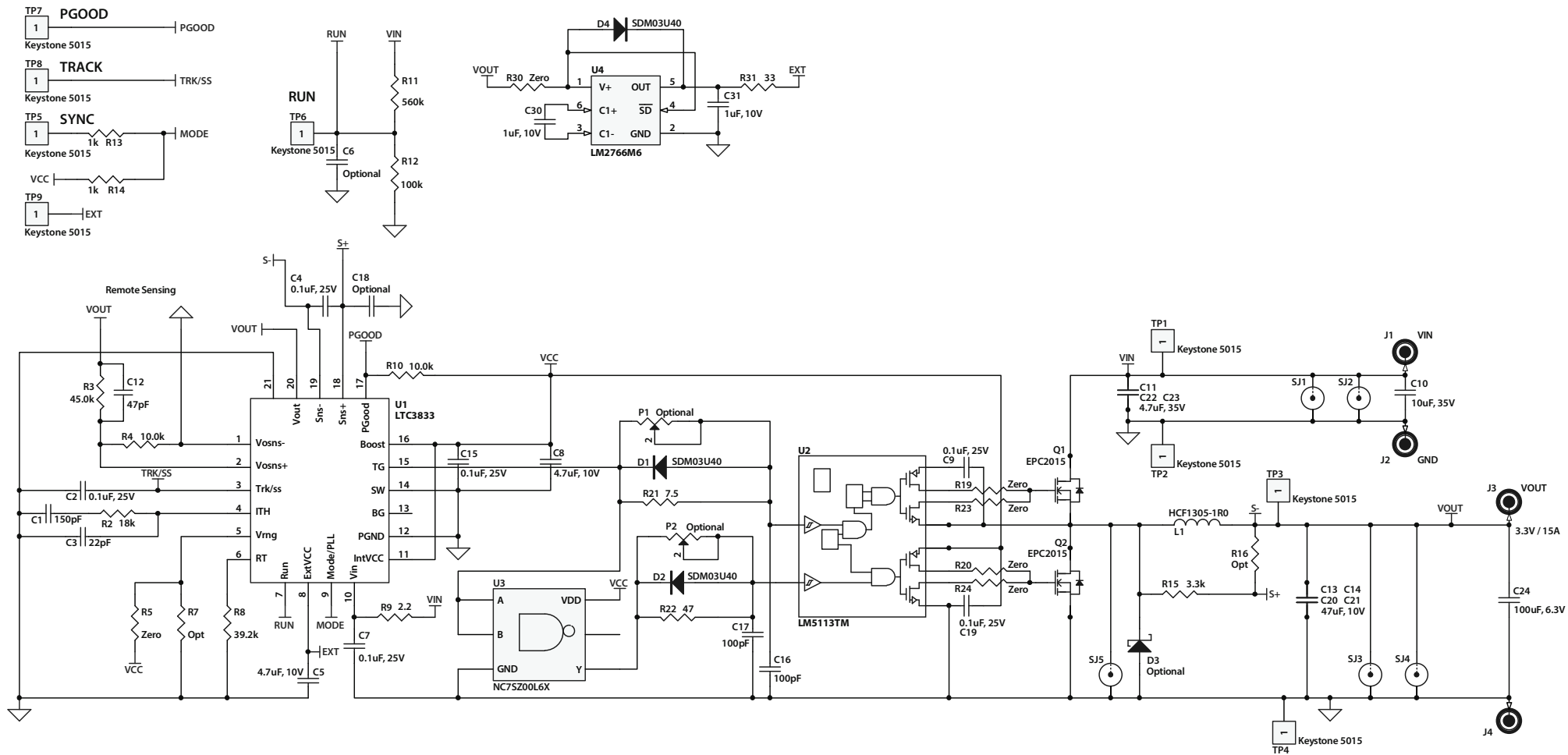

Figure 6: Thermal image of EPC9107 under full load condition: 28 V_{IN}, 15 A_{OUT} with convection cooling

Table 2 : Bill of Material

| Item | Qty | Reference | Part Description | Manufacturer / Part # |
|------|-----|---|--|------------------------------------|
| 1 | 1 | C1 | Capacitor, 150pF, 5%, 50V, NPO | Murata, GRM1885C1H151JA01D |
| 2 | 1 | C3 | Capacitor, 22pF, 5%, 50V, NPO | Murata, GRM1885C1H220JA01D |
| 3 | 1 | C12 | Capacitor, 47pF, 5%, 50V, NPO | TDK, C1608C0G1H470J |
| 4 | 6 | C2, C4, C7, C9, C15, C19 | Capacitor, 0.1uF, 10%, 25V, X5R | TDK, C1005X5R1E104K |
| 5 | 2 | C5, C8 | Capacitor, 4.7uF, 10%, 10V, X5R | TDK, C1608X5R1A475K |
| 6 | 1 | C10 | Capacitor, 10uF, 20%, 35V, X5R | Taiyo Yuden, GMK325BJ106KN |
| 7 | 2 | C11, C22, C23 | Capacitor, 4.7uF, 10%, 35V, X7R | TDK, C2012X6S1V475K125AB |
| 8 | 4 | C13, C14, C20, C21 | Capacitor, 47uF, 20%, 10V, X5R | TDK, C2012X5R1A476M |
| 9 | 2 | C16, C17 | Capacitor, 100pF, 5%, 50V, NPO | Kemet, C0402C101K5GACTU |
| 10 | 1 | C24 | Capacitor, 100uF, 20%, 6.3V, X5R | Kemet, C1206C107M9PACTU |
| 11 | 2 | C30, C31 | Capacitor, 1uF, 20%, 10V, X5R | TDK, C1005X5R1A105K050BB |
| 12 | 2 | D1, D2, D4 | Schottky Diode, 30V | Diodes Inc., SDM03U40-7 |
| 13 | 4 | J1, J2, J3, J4 | Banana Jack | Keystone, 575-4 |
| 14 | 1 | L1 | Inductor, 1.0uH, 22A | Cooper Bussman, HCF1305-1R0-R |
| 15 | 2 | Q1, Q2 | eGaN® FET | EPC, EPC2015 |
| 16 | 1 | R3 | Resistor, 45.0k, 1%, 1/8W | Stackpole, RMCF0603FT45K3 |
| 17 | 2 | R4, R10 | Resistor, 10.0k, 1%, 1/10W | Panasonic, ERJ-2RKF1002X |
| 18 | 6 | R5, R19, R20, R23, R24, R30 | Resistor, 0 Ohm, 1/16W | Stackpole, RMCF0402ZT0R00 |
| 19 | 1 | R31 | Resistor, 39 Ohm, 1%, 1/16W | Stackpole, RMCF0402FT39R0 |
| 20 | 1 | R8 | Resistor, 39.2k, 1%, 1/8W | Stackpole, RMCF0603FT39K2 |
| 21 | 1 | R2 | Resistor, 18.0k, 1%, 1/8W | Stackpole, RMCF0603FT18K0 |
| 22 | 1 | R9 | Resistor, 2.2 Ohm, 5%, 1/16W | Yageo, RC0402FR-072R2L |
| 23 | 1 | R11 | Resistor, 560K, 1%, 1/8W | Stackpole, RMCF0603FT560K |
| 24 | 1 | R12 | Resistor, 100k, 1%, 1/8W | Stackpole, RMCF0603FT100K |
| 25 | 2 | R13, R14 | Resistor, 1.00k, 5%, 1/10W | Rohm, MCR03EZPJ102 |
| 26 | 1 | R15 | Resistor, 3.3k, 5%, 1/8W | Stackpole, RMCF0603JT3K30 |
| 27 | 1 | R21 | Resistor, 7.5 Ohm, 5%, 1/16W | Stackpole, RMCF0603JT7R50 |
| 28 | 1 | R22 | Resistor, 47 Ohm, 5%, 1/16W | Stackpole, RMCF0603JT47R0 |
| 29 | 9 | TP1, TP2, TP3, TP4, TP5, TP6, TP7, TP8, TP9 | Measurement Point | Keystone Elect, 5015 |
| 30 | 1 | U1 | I.C., Buck Regulator | Linear Technology, LTC3833EUDC#PBF |
| 31 | 1 | U2 | I.C., Gate Driver | Texas Instruments, LM5113 |
| 32 | 1 | U3 | I.C., Logic | Fairchild, NC7SZ00L6X |
| 33 | 1 | U4 | I.C., Charge Pump | Texas Instruments, LM2766M6 |
| 34 | 4 | | Nylon Stand-offs | Keystone, 8834 |
| 35 | 0 | P1, P2 | Optional Potentiometer, 500 Ohm, 0.25W | |
| 36 | 0 | R7, R16 | Optional Resistors | |
| 37 | 0 | C6, C18 | Optional Capacitors | |
| 38 | 0 | SJ5 | Optional Scope Jack | |
| 39 | 0 | D3 | Optional Diode | |
| 40 | 0 | SJ1, SJ2, SJ3, SJ4 | Optional SMA connectors | |



**Demonstration Board –
EPC9107 Schematic**
Rev. 1.0

Contact us:

www.epc-co.com

Renee Yawger

WW Marketing

Office: +1.908.475.5702

Mobile: +1.908.619.9678

renee.yawger@epc-co.com

Stephen Tsang

Sales, Asia

Mobile: +852.9408.8351

stephen.tsang@epc-co.com

Bhasy Nair

Global FAE Support

Office: +1.972.805.8585

Mobile: +1.469.879.2424

bhasy.nair@epc-co.com

Peter Cheng

FAE Support, Asia

Mobile: +886.938.009.706

peter.cheng@epc-co.com



EPC Products are distributed exclusively through Digi-Key.

www.digikey.com

Demonstration Board Notification

The EPC9107 board is intended for product evaluation purposes only and is not intended for commercial use. As an evaluation tool, it is not designed for compliance with the European Union directive on electromagnetic compatibility or any other such directives or regulations. As board builds are at times subject to product availability, it is possible that boards may contain components or assembly materials that are not RoHS compliant. Efficient Power Conversion Corporation (EPC) makes no guarantee that the purchased board is 100% RoHS compliant. No Licenses are implied or granted under any patent right or other intellectual property whatsoever. EPC assumes no liability for applications assistance, customer product design, software performance, or infringement of patents or any other intellectual property rights of any kind.

EPC reserves the right at any time, without notice, to change said circuitry and specifications.