

DO NOT SCALE FROM THIS PRINT

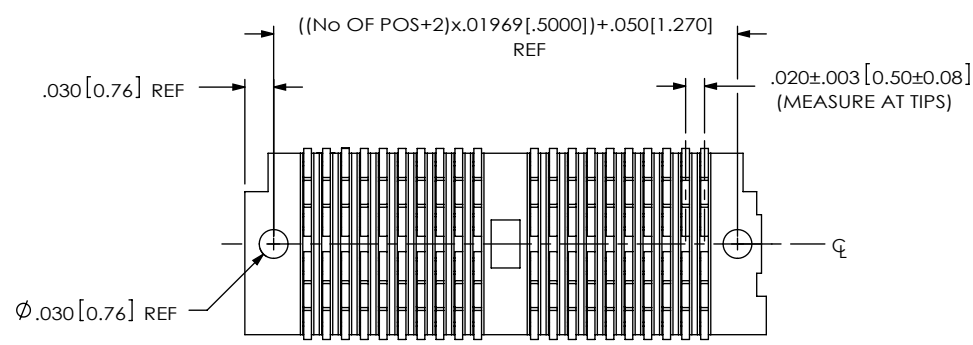

- NOTES:
1. Ⓢ REPRESENTS A CRITICAL DIMENSION.
 2. BURR ALLOWANCE: .001 [0.03] MAX.
 3. MINIMUM PUSHOUT FORCE: 6 OZ MIN.
 4. PARTS TO BE MOLDED TO POSITION
 5. NOTE DELETED.
 6. CUT IN THIS AREA MUST BE BELOW SURFACE MOUNT LEADS.
 7. MAX VARIATION BETWEEN ADJACENT PINS TO BE .002 [0.05] MAX.
 8. NOTE DELETED.
 9. NOTE DELETED.
 10. VOIDS CAN BE USED AT VENDORS DISCRETION TO CONTROL WARP.

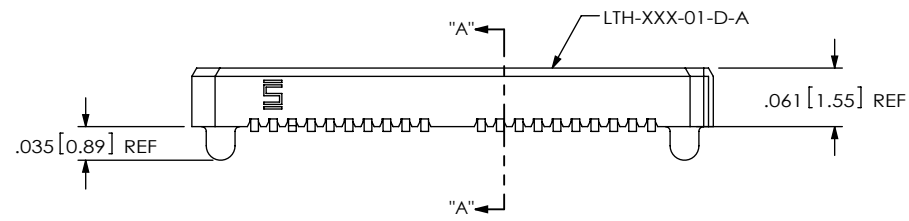
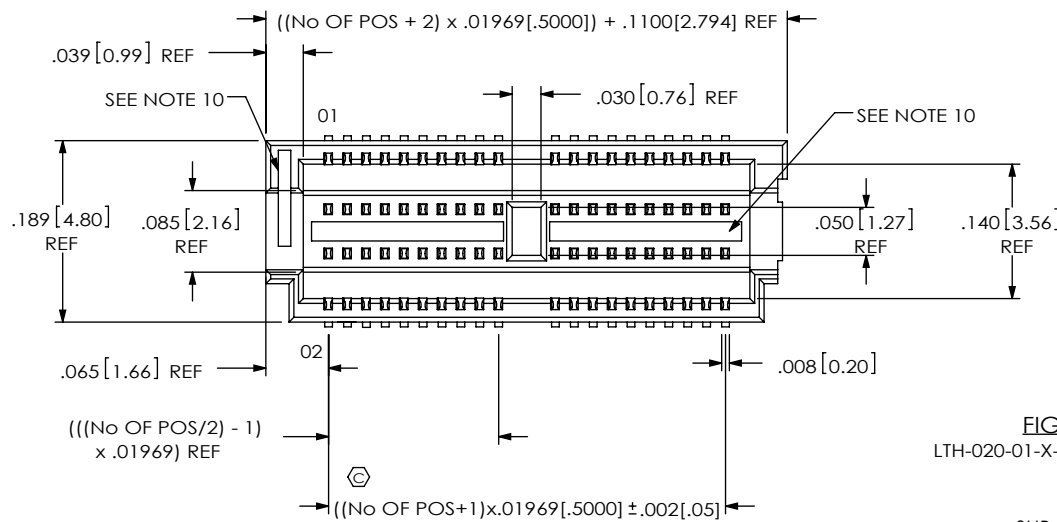
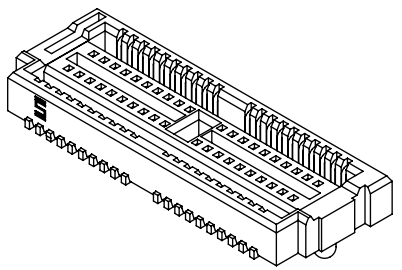

LTH-XXX-XX-X-D-A-XX

- No OF POSITIONS**
-010, -020, -030, -040, -050, (PER ROW)
- LEAD STYLE**
-01: SURFACE MOUNT (USE SUB-T-1M18-01-X PIN)
- PLATING SPECIFICATION**
-G: 10μ" GOLD IN CONTACT AREA, 3μ" GOLD ON TAIL
-H: 30μ" HEAVY GOLD IN CONTACT AREA, 3μ" GOLD ON TAIL
- OPTION**
-TR: TAPE AND REEL
-K: POLYAMIDE FILM PAD (USE K-500-300, SEE FIG. 2)
- A: ALIGNMENT PIN**
- ROW SPECIFICATION**
-D: DOUBLE (USE LTH-XXX-01-D-A)

FIG 1
LTH-020-01-X-D-A SHOWN

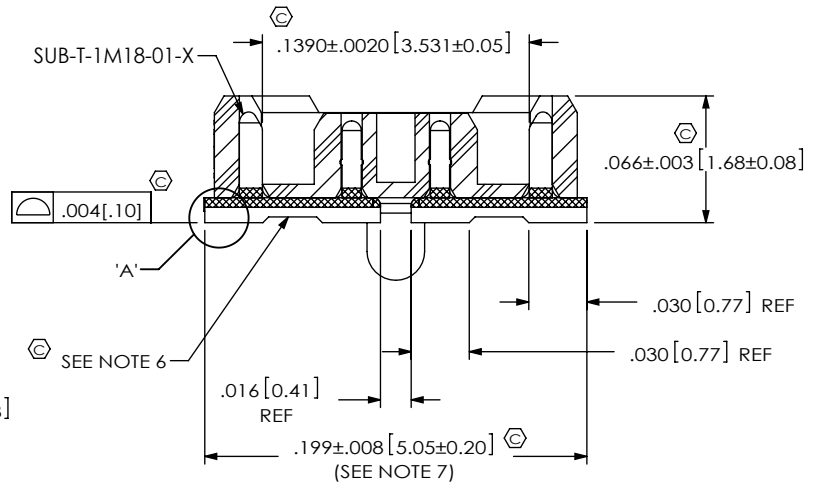

SECTION "A"-A"
SCALE 10 : 1

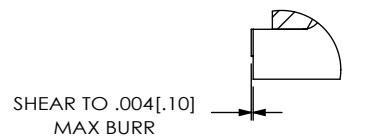

DETAIL 'A'
SCALE 20 : 1

| | | | |
|--|--|--|---|
| <p>UNLESS OTHERWISE SPECIFIED, DIMENSIONS ARE IN INCHES. TOLERANCES ARE:</p> <p>DECIMALS ANGLES</p> <p>.XX: ±.01 [3] 2°</p> <p>.XXX: ±.005 [13]</p> <p>.XXXX: ±.0020 [051]</p> | <p>PROPRIETARY NOTE</p> <p>THIS DOCUMENT CONTAINS INFORMATION CONFIDENTIAL AND PROPRIETARY TO SAMTEC, INC. AND SHALL NOT BE REPRODUCED OR TRANSFERRED TO OTHER DOCUMENTS OR DISCLOSED TO OTHERS OR USED FOR ANY PURPOSE OTHER THAN THAT WHICH IT WAS OBTAINED WITHOUT THE EXPRESSED WRITTEN CONSENT OF SAMTEC, INC.</p> | <p>520 PARK EAST BLVD, NEW ALBANY, IN 47150 PHONE: 812-944-6733 FAX: 812-948-5047 e-Mail: info@SAMTEC.com code: 55322</p> | |
| | | <p>MATERIAL: DO NOT SCALE DRAWING SHEET SCALE: 5:1</p> <p>INSULATOR: BLACK LCP</p> <p>CONTACT: PHOS. BRONZE</p> | <p>DESCRIPTION: .5mm LOW PROFILE TERMINAL ASSEMBLY</p> <p>DWG. NO. LTH-XXX-XX-X-D-A-XX</p> |
| <p>F:\DWG\MISC\MKTG\LTH-XXX-XX-X-D-A-XX-MKT.SLDDRW</p> | | <p>BY: ERIC M 7/1/99</p> | <p>SHEET 1 OF 2</p> |

FIG 2
-K: POLYAMIDE FILM PAD
[USE K-500-300]

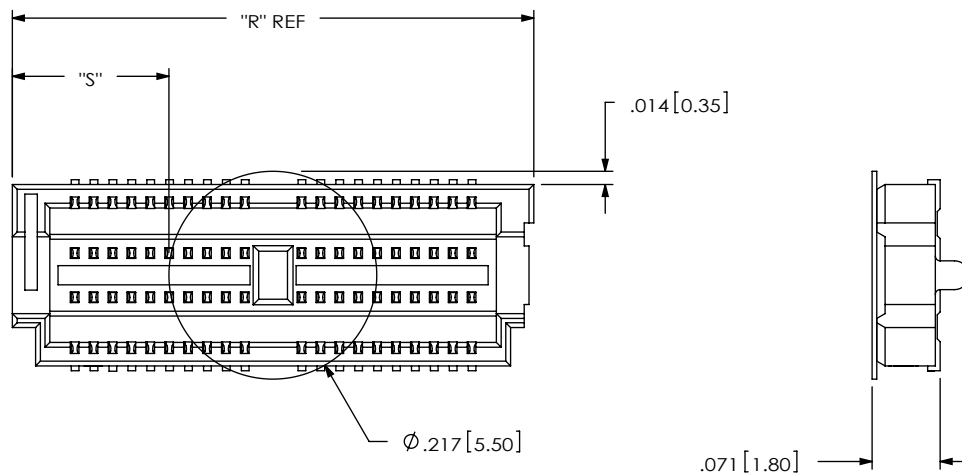

NOTE: "R" = ((No OF POSITIONS + 2) x .01969[.5000]) + .1100[2.794]
 "S" = (("R" - .217[5.50]) / 2) ±.020[.51]

PACKAGING VIEW

(PARTS TO HAVE POSITIONS #1 LOADED
 IN SAME DIRECTION AS ARROW ON TUBE)
 TUBE IS USED FOR PARTS WITH OR WITHOUT -K OPTION

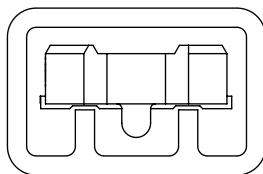

TUBE: PT-1-24-01-96
 PLUG: TP-12

PROPRIETARY NOTE
 THIS DOCUMENT CONTAINS INFORMATION
 CONFIDENTIAL AND PROPRIETARY TO
 SAMTEC, INC. AND SHALL NOT BE REPRODUCED
 OR TRANSFERRED TO OTHER DOCUMENTS OR
 DISCLOSED TO OTHERS OR USED FOR ANY
 PURPOSE OTHER THAN THAT WHICH IT WAS
 OBTAINED WITHOUT THE EXPRESSED WRITTEN
 CONSENT OF SAMTEC, INC.

DO NOT SCALE DRAWING

SHEET SCALE: 5:1



520 PARK EAST BLVD, NEW ALBANY, IN 47150
 PHONE: 812-944-6733 FAX: 812-948-5047
 e-Mail: info@SAMTEC.com code: 55322

DESCRIPTION: .5mm LOW PROFILE TERMINAL ASSEMBLY

DWG. NO. LTH-XXX-XX-X-D-A-XX

BY: ERIC M 7/1/99 SHEET 2 OF 2