

Description	Material	Finish
Body	Brass	Nickel
Socket	BE CU	Gold
Insulation	PTFE	N/A
Washer	PH Bronze	Nickel
Gasket	SI Rubber	Rubber
Crimp Ring	Brass	Nickel
Insulator	PTFE	N/A
Cover	Brass	Nickel
Heat Shrink	Polyolefin	Black

REVISIONS			
REV	DESCRIPTION	DATE	APPV
B	Changed crimp ring dimensions; added heat shrink, new title block and assembly instructions	2-JUL-12	SAH

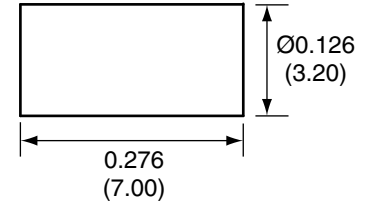

CRIMP RING

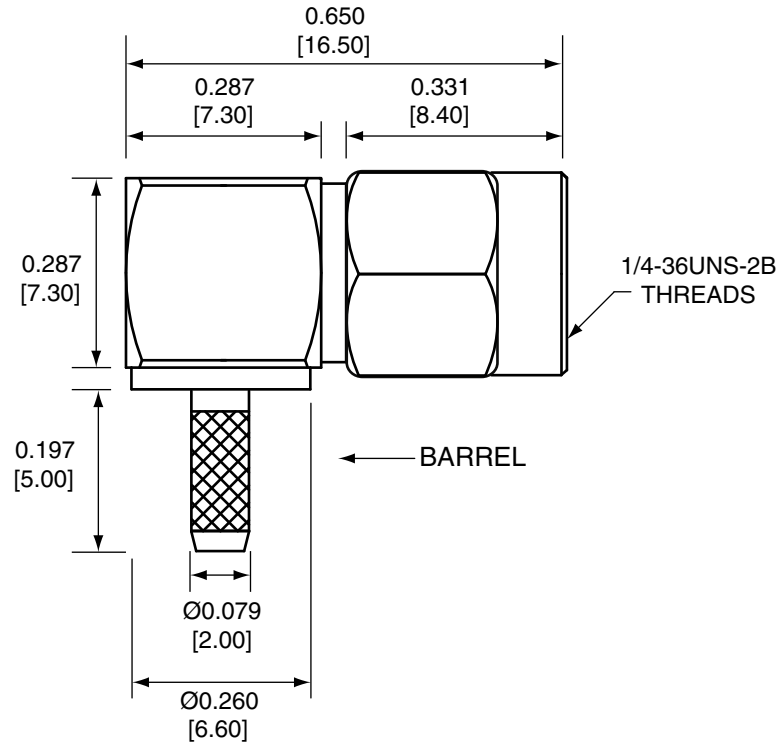
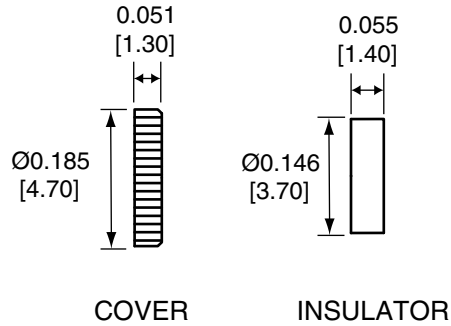
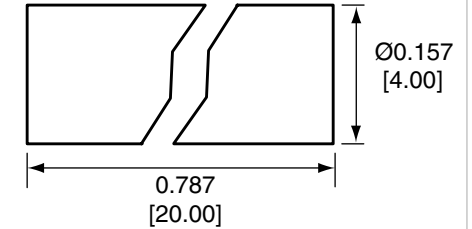

HEAT SHRINK

**CONREV SMA012-R178 ASSEMBLY INSTRUCTIONS**

1. Strip the cable to the recommended dimensions.
2. Slip heat shrink and crimp ring onto stripped cable.
3. Slide the cable into the body until the center conductor is centered in the fork.
4. Push the braided shield over the barrel.
5. Solder the center conductor into the center of the fork.
6. Slide the crimp ring over the shield and crimp with a 0.100" hex crimp tool.
7. Trim off any excess shield wire sticking out from the ring.
8. Slip the heat shrink over the crimp ring until it is against the body and shrink.
9. Insert insulator into body.
10. Push the cover into the opening.

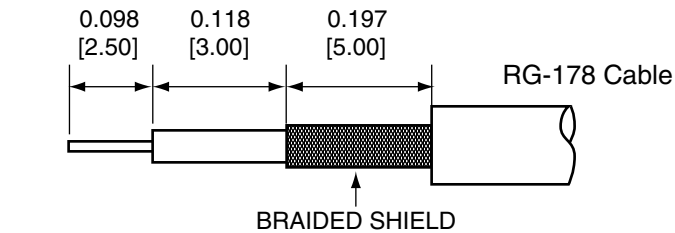

RECOMMENDED CABLE STRIPPING DIMENSIONS

SIDE VIEW

NOTES: (UNLESS OTHERWISE SPECIFIED)

1. ALL DIMENSIONS ARE IN INCHES [mm].
2. DIMENSIONS APPLY AFTER FINISHING.
3. MANUFACTURE TO BE COMPLIANT WITH EU RoHS DIRECTIVE.
4. SAFETY BREAK ALL SHARP CORNERS AND EDGES .02 MAXIMUM.

**WARNING:** THIS DRAWING CONTAINS PROPRIETARY INFORMATION THAT IS THE SOLE PROPERTY OF LINX TECHNOLOGIES, AND SHALL BE TREATED AS SUCH. NO DISCLOSURE OR REPRODUCTION OF THIS DOCUMENT IS PERMITTED, IN WHOLE OR IN PART, WITHOUT THE EXPRESS WRITTEN PERMISSION OF LINX TECHNOLOGIES OR ITS DESIGNATED AGENTS.

MATERIAL:	TOLERANCES:	PROJECTION:
	.020 [0.50]-.200 [5.00]= ±.008 [0.20] .200 [5.00]-1.200 [30.00]= ±.016 [0.40] 1.20 [30.0]-4.75 [120.0]= ±.024 [0.60] 4.75 [120.0]-12.40 [315.0]= ±.040 [1.0]	ANGLES: ±1°
FINISH:	DRAWN: B.MURPHY	DT: 2-JUL-12
	ENGR: S.HOGAN	DT: 2-JUL-12

**Linx**

159 ORT LANE  
MERLIN, OR 97532

TITLE:  
**RP-SMA MALE RIGHT ANGLE  
CABLE END CRIMP FOR RG178 CABLE**

SIZE	DWG. NO.	REV
<b>A</b>	<b>CONREV SMA012-R178</b>	<b>B</b>
SCALE: 2:1	DO NOT SCALE DRAWING	SHEET 1 OF 1