

# Quick Start Guide



**TDINV3500P100\_0v1**

**Evaluation Platform**

**3.5kW inverter**

**transphorm**



Highest Performance, Highest Reliability GaN

11/2017



# Equipment Needed

- ➔ The TDINV3500P100\_Ov1 board
- ➔ Texas Instruments F28035 control card (included)
- ➔ Low-voltage DC power supply for auxiliary voltage
  - 12V power supply (included)
- ➔ High-voltage DC power supply
  - 1000V maximum
  - 3.5kW capable
- ➔ Resistor load for 500V<sub>AC</sub>/3.5kW
  - Must be isolated from high-voltage DC power supply
- ➔ Firmware for programming and advanced configuration (included)



## Cautions and Warnings



This evaluation board is intended to demonstrate GaN FET technology and is for demonstration purposes only and no guarantees are made for standards compliance.

There are areas of this evaluation board that have exposed access to hazardous high voltage levels. Exercise caution to avoid contact with those voltages. Also note that the evaluation board may retain high voltage temporarily after input power has been removed. Exercise caution when handling.

When testing converters on an evaluation board, ensure adequate cooling. Apply cooling air with a fan blowing across the converter or across a heatsink attached to the converter. Monitor the converter temperature to ensure it does not exceed the maximum rated per the datasheet specification.

# Step 1: Connect the Board

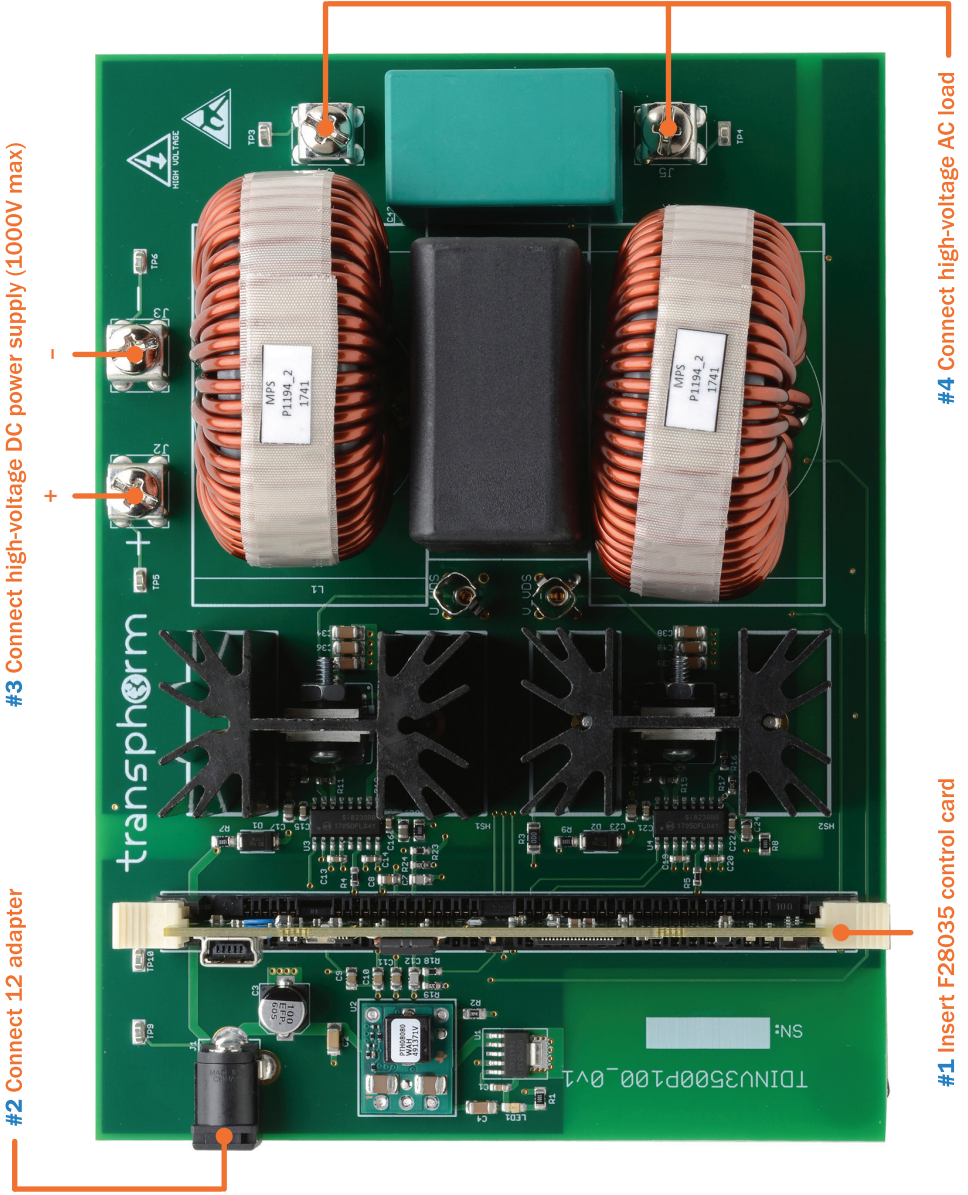

## Note:

DO NOT apply too much force to the J2, J3, J4 and J5 connectors, as excessive force may bend and/or crack the PCB.

# Circuit Diagram

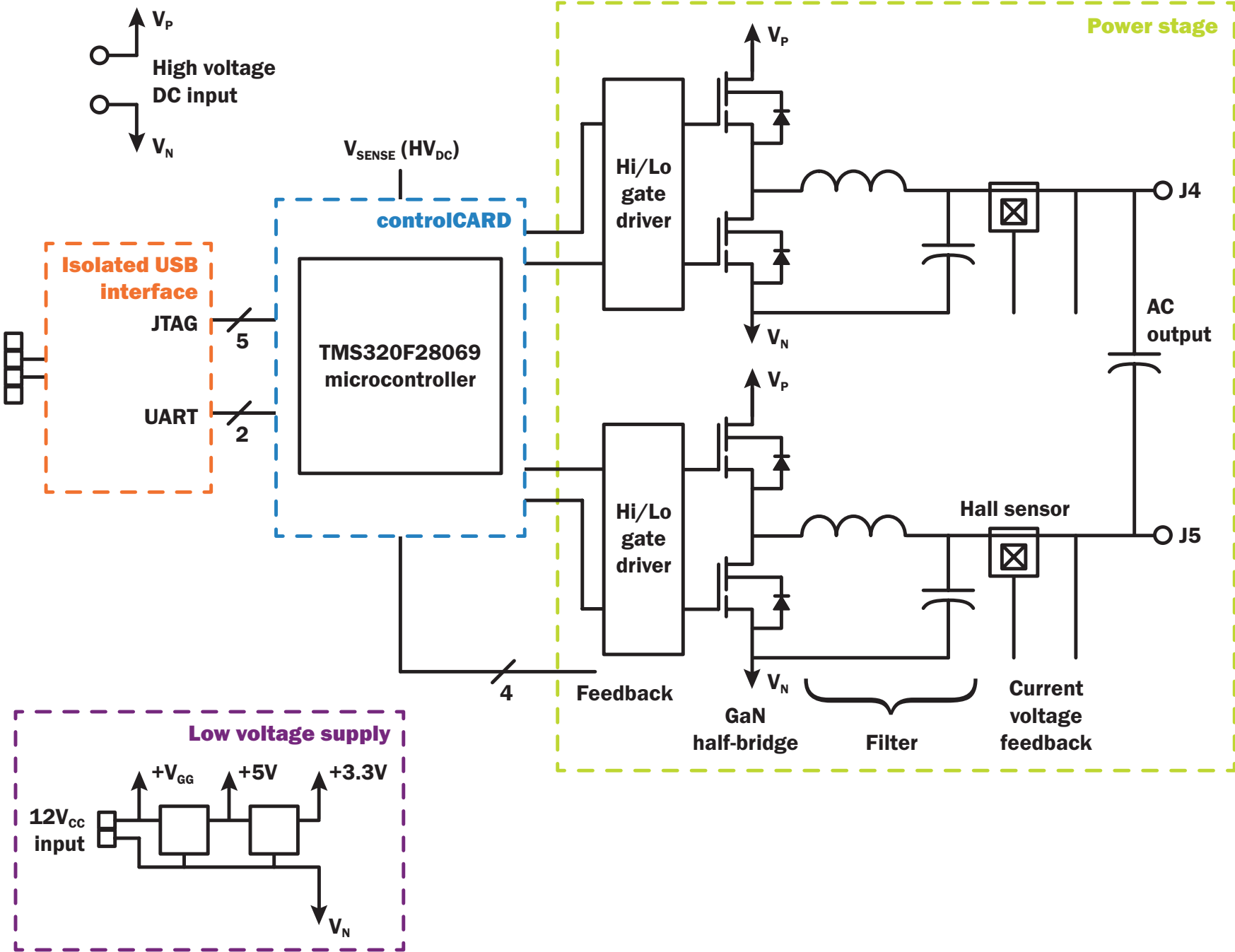

## Step 2: Power-up the Board

- Insert the control card
  - LED1 ON indicates DSP power is on
  - LED2 ON indicates the DSP is running
  - LED2 + LED3 BLINKING indicates the DSP has stopped running due to fault protection (over voltage or current) - the board will need to be power cycled to reset the protections
- Connect high-voltage power supply to the +/- inputs (J2 and J3)
- Set output (J4 and J5) load to handle ~50W
- Insert  $V_{CC}$  (12V) plug to J1
  - LED1 should illuminate, indicating power is applied to the 5V and 3.3V regulators

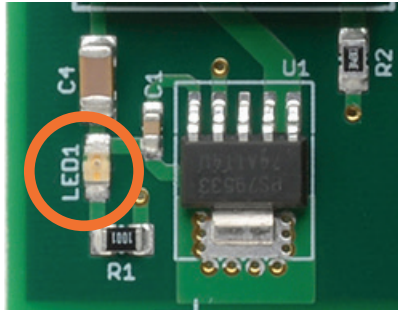

- Turn on high-voltage power supply
  - The high-voltage supply may be switched on or raised gradually
  - Gradually increase the input voltage to desired value while monitoring output voltage/waveform

## Step 3: Power-down the Board

- Switch off the high-voltage DC supply
- Power off the 12V aux supply

### Note:

Normal operation is 730V<sub>DC</sub> (in) and 500V<sub>AC</sub> (out) for 3.5kW power at 100kHz. Monitor the output voltage waveforms—see Typical Waveforms with Stock Firmware on page 6.

# Typical Waveforms with Stock Firmware

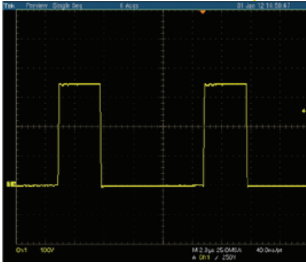
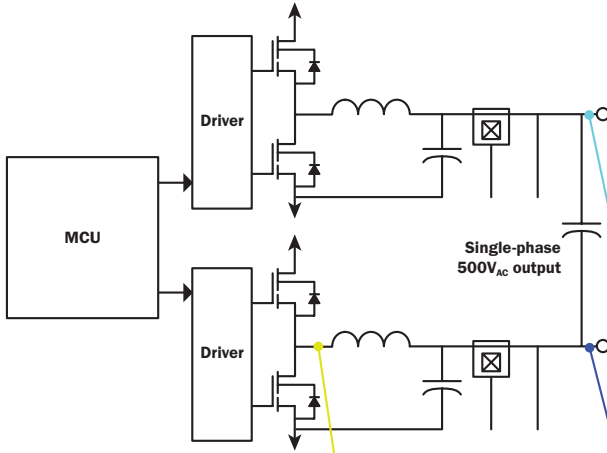

100kHz switching waveform

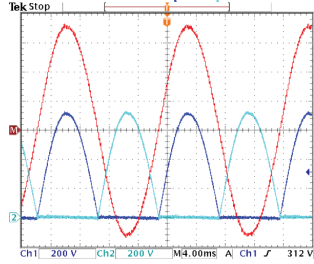

60Hz output voltages and current

# Typical Performance Curves

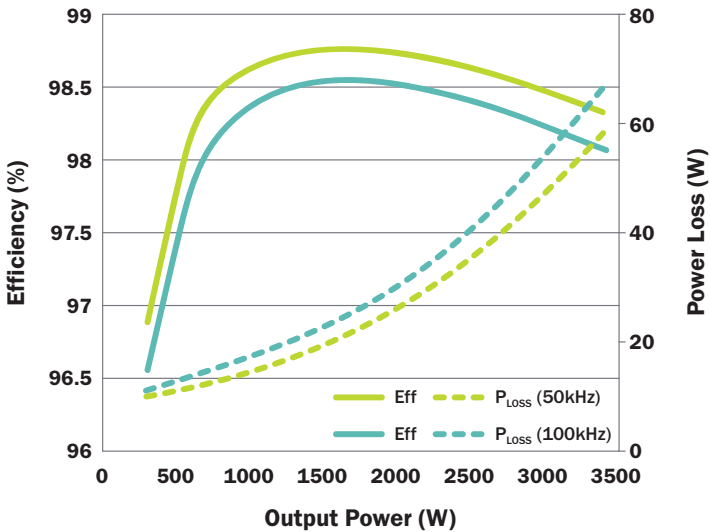



transphorm

+1 805 456 1300  
[transphormusa.com](http://transphormusa.com)

TDINV3500P100\_0v1  
For evaluation purposes only

Design files and more at  
[transphormusa.com/pv35kit](http://transphormusa.com/pv35kit)